

# Panasonic

# AG-2580

Hi-Fi Stereo VHS Video Cassette Recorder  
(NTSC)



Hi-Fi



SQPB

- Hi-Fi VHS Stereo
- Easy Programming Options
- Advanced Jog Dial on VCR
- Plug & Play
- SQPB (S-VHS Quasi Playback)
- Auto Picture
- Picture Control



VHS

# AG-2580 Hi-Fi Stereo VHS Video Cassette Recorder

## Hi-Fi VHS Stereo

This Hi-Fi VCR's broad dynamic range delivers sound quality rivaling CDs for an impressive home theater experience.

## S-VHS Quasi Playback

The AG-2570 is equipped with circuitry that allows playback of S-VHS tapes at standard VHS resolution.

## Auto Picture

The intelligent IC automatically judges the quality of the tape and assesses the condition of the video heads, optimizing and maintaining playback performance for the lifetime of the VCR.

## Plug & Play

Makes set-up and installation virtually effortless! Simply take the VCR out of the box, hook-up the antenna or cable and then plug in the VCR. Within 3 minutes all your channels will have been locked in; your day, date, and time will have been set. Auto Clock Set. It's that simple.

## Picture Control

User can select the best viewing from 4 settings modes on the VCR based on their preferences and program content.

**(Auto/Normal)** Provides the optimized picture benefits of the Auto Picture/Active Video Calibration System.

**(Soft)** Reduces image coarseness when viewing overlaid tapes containing a lot of noise.

**(Edit)** Minimizes picture degradation during editing (recording and playback).

**(Sharp)** Clearer, sharper-edged picture when viewing images with lots of flat, same-colored surfaces such as cartoons.

## Advanced Jog Dial

Everything from frame-by-frame playback to variable-speed slow motion, search and pause are precisely controllable by push-and turning operation of the Jog Dial right on the front panel.

## VCR Plus+

VCR time-shift recording feature system included in many VCR's. Uses special Plus codes, (found in most channel guides) multi-digit numbers that identify each broadcast program, channel number, and time of broadcast.



## Instant Review

Instant Review enables fast, simple playback of timer-recorded programs.

## Additional Features

- Dual Azimuth - 4 Video Heads
- Hi-Fi Stereo Sound
- Auto Index
- Auto SP - EP Timer Recording
- 1 Year / 8 Event Timer
- Multi-Brand TV/Cable/DBS Compatible Remote w/ Glow Keys
- Pro-Cision 19 micron width EP Heads
- AV Compu Link
- Rear AV Inputs, Gold Plated Front AV Inputs
- AV Outputs on Rear Panel
- 181 Channel Tuner
- Multi Lingual Color On Screen Menu. Menu Button on VCR.

## Dimensions

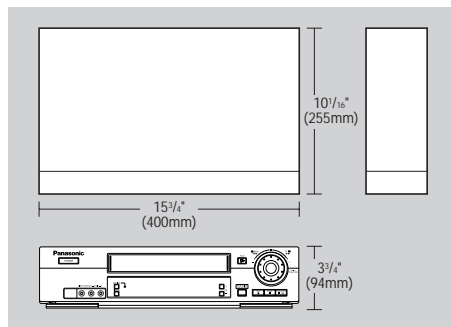

**Warning:** Unauthorized recording of copyrighted television programs, films, video tapes and other materials may infringe upon the rights of copyright owners and be contrary to copyright laws.

Weight and dimensions shown are approximate. Specifications subject to change without notice. This is product may be subject to export control regulations. VCR Plus+ C3 and PlusCode are trademarks of Gemstar Development Corporation. The VCR Plus+ system is Manufactured under license from Gemstar Development Corporation.

## Specifications

<b>GENERAL</b>	
Power requirement :	AC 120 V , 60 Hz
Power consumption	
Power on :	18 W
Power off :	2.0 W
<b>Temperature</b>	
Operating :	5°C to 40°C (41°F to 104°F)
Storage :	-20°C to 60°C (-4°F to 140°F)
Operating position :	Horizontal only
Dimensions (W x H x D) :	400 mm x 94 mm x 255 mm (15-3/4" x 3-3/4" x 10-1/16")
Weight :	3.1 kg (6.8 lbs)
Format :	VHS NTSC standard
<b>Maximum recording time</b>	
SP :	210 min. with 210 min. video cassette
EP :	630 min. with 210 min. video cassette
<b>VIDEO/AUDIO</b>	
Signal system :	NTSC-type color signal and EIA monochrome signal, 525 lines/60 fields
Recording/Playback system :	
	Double Azimuth 4 head helical scan system
Signal-to-noise ratio :	45 dB
Horizontal resolution :	230 lines
Frequency range	
Normal audio :	70 Hz to 10,000 Hz
Hi-Fi audio :	20 Hz to 20,000 Hz
Input/Output :	PHONO connectors (IN x 2, OUT x 1)
<b>TUNER</b>	
Tuning system :	Frequency-synthesized tuner
Channel coverage	
VHF :	Channels 2-13
UHF :	Channels 14-69
CATV :	113 Channels
RF output :	Channel 3 or 4 (switchable; preset to Channel 3 when shipped) 75 ohms, unbalanced
<b>TIMER</b>	
Clock reference :	Quartz
Program capacity :	1-year programmable timer/8 programs
Memory backup for timer is not supported.	
<b>ACCESSORIES</b>	
Provided accessories :	RF cable, Infrared remote control unit, "AA" battery x 2, Cable Box Controller

Specifications shown are for SP mode unless specified otherwise. E. & O.E. Design and specifications subject to change without notice.



# Panasonic

## PANASONIC BROADCAST & TELEVISION SYSTEMS COMPANY

DIVISION OF MATSUSHITA ELECTRIC CORPORATION OF AMERICA  
www.panasonic.com/broadcast

**Executive Office:** One Panasonic Way 4E-7, Secaucus, NJ 07094  
(201) 348-5300

**EASTERN ZONE:** One Panasonic Way 4E-7, Secaucus, NJ 07094  
(201)348-7196

**Central Region:** 1707 N Randall Road E1-C-1, Elgin, IL 60123 (847) 468-5200

**WESTERN ZONE:** 3330 Cahuenga Blvd W., Los Angeles, CA 90068  
(323) 436-3608

**Government Marketing Department:**  
52 West Guide Drive, Rockville, MD 20850 (301) 738-3840

**Panasonic Canada Inc.**  
5770 Ambler Drive, Mississauga, Ontario L4W 2T3 (905) 624-5010  
www.panasonic.ca e-mail: broadcast@panasonic.ca

**Panasonic Sales Company**  
(Division of Matsushita Electric of Puerto Rico Inc.)  
San Gabriel Industrial Park, 65th Infantry Ave., Km. 9.5, Carolina,  
Puerto Rico 00630 (787) 750-4300

**Matsushita Electric Industrial Co., Ltd.**  
**Systems Business Group**  
2-15 Matsuba-cho, Kadoma, Osaka, 571-8503 Japan  
Tel. 81-6-6905-4650 Fax. 81-6-6908-5969  
www.panasonic.co.jp/btd

**Panasonic Systems Sales Taiwan Co., Ltd.**  
5F, 2 Sec. 5 Hsin I Road Taipei, Taiwan, R.O.C  
Tel. 886-2-2725-9100 Fax. 886-2-2725-9291

**DaeHeung Multimedia Communication Corp.**  
4th Fl, Kyobo Securities Bldg., 26-4, Youngdungpo-Gu,  
Seoul, Korea Tel. 82-2-784-0245 Fax. 82-2-784-0109

**Broadcast and Communication Company of Asia, Inc.**  
R-1902A Tektite Tower II Exchange Road Ortigas Center  
Posig City, Philippines  
Tel. 63-2-633-6162 Fax. 63-2-631-1861  
**Panasonic de Mexico, S.A. de C.V.**  
Tel. 52-5-488-1000 Fax. 52-5-488-1059

**Panasonic Latin America S.A.**  
(Caribe, Centro America, Venezuela, Colombia, Ecuador, Bolivia,  
Uruguay, Paraguay, Chile)  
Tel. 507-229-2955 Fax. 507-229-2536

**Panasonic del Peru S.A.**  
Tel. 51-1-451-3638 Fax. 51-1-452-9415

**Panasonic do Brasil Ltda**  
Tel. 55-11-3889-4035 Fax. 55-11-3889-4004

